

Part No. P0937665 Issue 02

# **Business Communications Manager**

## **i2004 Internet Telephone User Card**



**NORTEL**  
**NETWORKS™**



---

## Getting started

---

The Business Communications Manager i2004 Internet Telephone brings voice and data to your desktop.

### Introduction

This card contains information about:

- telephone buttons and lights
- telephone display
- telephone setup
- how to make and answer calls
- how to use the navigation buttons
- how to program memory buttons
- how to offset the time on your telephone display

Figure 1 shows the i2004 Internet Telephone.

**Figure 1** The i2004 Internet Telephone

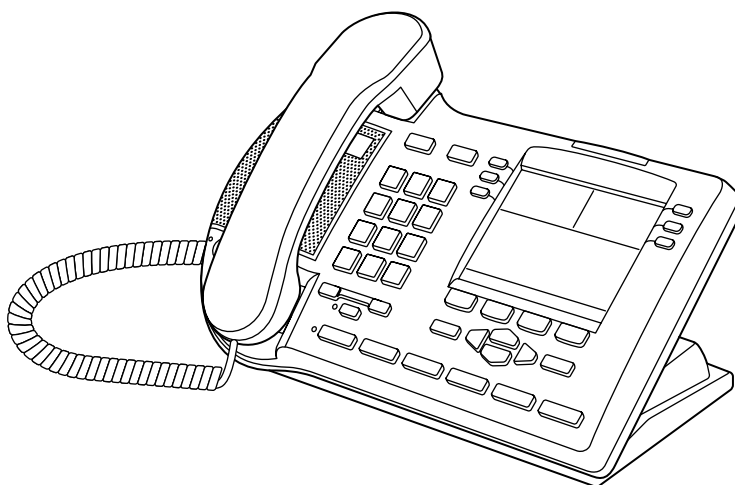

## i2004 button and light descriptions

Figure 2 shows the i2004 Internet Telephone lights and buttons.

**Figure 2** i2004 Internet Telephone buttons

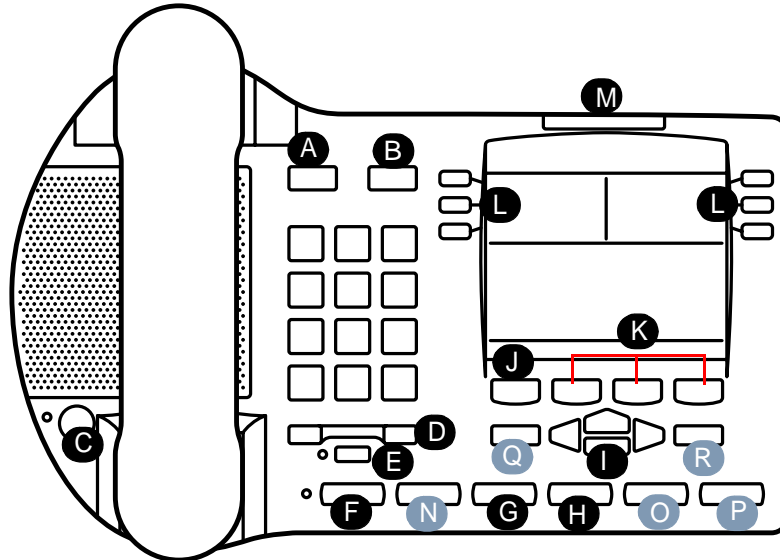



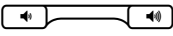















Table 1 shows a description of the lights and buttons.

**Table 1** i2004 Internet Telephone buttons and descriptions

<b>A</b>		<b>Hold button</b> Places an active call on hold.
<b>B</b>		<b>Goodbye button</b> Ends an active call.
<b>C</b>		<b>Handsfree button with LED</b> Turns the Handsfree mode on.
<b>D</b>		<b>Volume control bar</b> Adjusts the handset, Handsfree, headset and ringer volume.
<b>E</b>		<b>Mute button with LED</b> Turns the microphone off and on when you are on a call.
<b>F</b>		<b>Headset button with LED</b> Turns the headset mode on.
<b>G</b>		<b>Mailbox in button</b> Opens your CallPilot mailbox. For more information about mailbox options, refer to your <i>CallPilot Quick Reference Card</i> .

- H**  **Leave Message button**  
Allows you to send voice mail messages. For more information on voice mail messaging, refer to your *CallPilot Quick Reference Card*.
- I**  **Navigation cluster buttons**  
Allows you to view items stored in your Call Log. For more information on the Call Log feature, refer to [“Navigation buttons” on page 11](#).
- J** **Feature**  **Feature button**  
Starts or ends a feature.
- K**  **Display buttons**  
Shows feature options.
- L**  **Line and Memory buttons**  
For more information on line and memory buttons, refer to [“Program memory buttons” on page 12](#).
- M**  **Telephone light**  
Flashes when a call rings at the telephone.  
Lights up when **Message for you** appears on the display.

The following buttons are reserved for future development, and are therefore not yet implemented.

- N**  **Directory button**
- O**  **Services button**
- P**  **PC Expansion button**
- Q**  **Quit button**
- R**  **Copy button**

## i2004 telephone display

There are three areas to the i2004 telephone display:

- Button label area
- Information area
- Feature options area

Figure 3 shows an example of the display and describes each area.

Figure 3 Display area

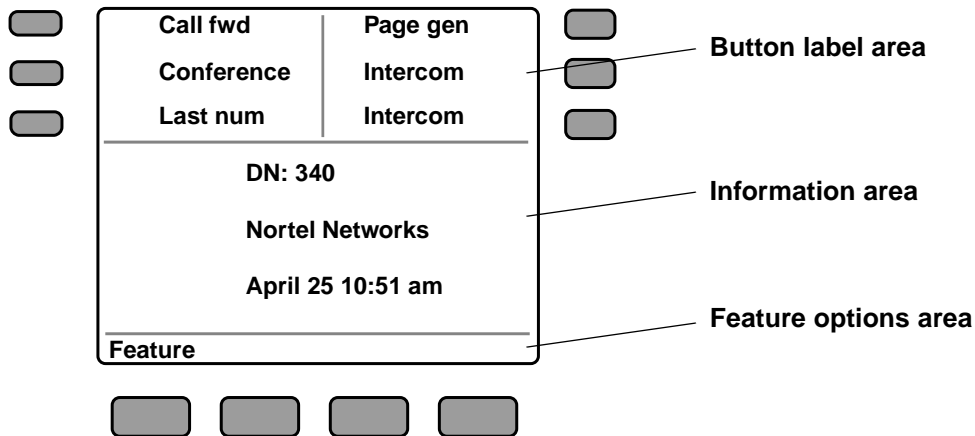

## Button label area

The button label area shows the label and status of the six programmable memory buttons. For more information about these buttons, refer to [“Program memory buttons” on page 12](#).

## Information area

The Information area shows:

- the extension number of the telephone (DN: 340)
- a line for general information (Nortel Networks)
- the date and time when the telephone is not in use, and changes to show features and call information when the telephone is in use

## Feature options area

When a feature is activated, or when you are on an active call, the display command line shows you the action you must take to proceed.

For example: **Pswd**. This means you must enter your mailbox password.

The Feature options area shows the label for the **FEATURE** button and for the three display buttons. These button labels appear in capital letters directly above the Feature and display buttons, and to the right of the **FEATURE** label on the display. These button labels vary depending on the feature in use.

## About your programmable buttons

Your System Administrator assigns the six programmable buttons as line, intercom or memory buttons. The label for each button appears on the display next to the button. For more information, see your System Administrator.

## Telephone setup

This section describes the i2004 Internet Telephone display features:

- Display contrast
- Language choice
- Ring type

**Note:** For more information about the features available to your telephone and how to use them, refer to the *Business Communications Manager Telephone Feature Card*.

### Display contrast level

Adjust the contrast for the telephone display.

- 1 Press **Feature** \* 7 .
- 2 Press **DOWN** and **UP** to view the levels.
- 3 Press **OK** to select a level.

### Language choice

Select the Primary Language for the telephone display.

- 1 Press **Feature** \* 5 0 1 .

Select the Alternate Language for the telephone display.

- 1 Press **Feature** \* 5 0 2 .

Select the Alternate Language 2 for the telephone display.

- 1 Press **Feature** \* 5 0 3 .

Select the Alternate Language 3 for the telephone display.

- 1 Press **Feature** \* 5 0 4 .

Select the Alternate Language 4 for the telephone display.

### Ring type

Select a different ring type for your telephone.

- 1 Press **Feature** \* 6 .
- 2 Press 1 , 2 , 3 , 4 , or **NEXT** or to hear the different ring types.
- 3 Press **OK** to store the ring type.



---

## Features and buttons

---

This section describes some of the i2004 Internet Telephone buttons and call features:

- Basic call features
- Navigation buttons
- Memory buttons

**Note:** For more information about the features available to your telephone and how to use them, refer to the *Business Communications Manager Telephone Feature Card*.

### Basic call features

You can make external and internal calls using the following features:

- make a call
- answer a call
- hold a call
- Handsfree
- headset
- Mute
- Time Offset

### Make a call

There are many ways to make a call depending on your telephone programming and the type of call.

#### External calls using line buttons

- 1 Lift the handset.
- 2 Press a line button.
- 3 Dial the external telephone number.

#### External calls using intercom buttons

- 1 Lift the handset.
- 2 Press an intercom button and enter a line pool access code.
- 3 When you hear an external dial tone, dial the external telephone number.

**Note:** Contact your System Administrator for a list of line pool codes. When entering a line pool access code on PRI lines you will not hear dial tone.

### Internal calls using intercom buttons

- 1 Lift the handset.
- 2 Press an intercom button.
- 3 Dial the extension number.



**Note:** Contact your System Administrator for a list of extension numbers.

### Answer calls

When your telephone rings and the light flashes or an intercom or line button  indicator flashes:





- lift the handset.
- OR
- press the line or intercom button with the flashing  indicator before you lift the handset.

### Hold

- Calls are put on hold automatically when you switch from one line to another.
- While on a call, press . The  indicator for the line on hold flashes.
- To retrieve a held call, press the line button with the flashing  indicator.





### Handsfree

Your System Administrator must program the Handsfree feature to your telephone.





- Press  to make or answer a call.
- To switch to Handsfree when you are on a handset call, press  and replace the handset. Lift the handset to switch back.
- To switch to Handsfree when you are on a headset call, press . Press  to switch back.

### Headset

You must have a headset installed on your telephone to use this feature.

- Press  to activate the headset mode. When the  light is on, press a line or intercom button to make a call.
- To switch to your headset when you are on a handset call, press  and replace the handset. Lift the handset to switch back.
- To switch to your headset when you are on a Handsfree call, press . Press  to switch back.







## Mute

- While on a call, press  to turn the microphone off. The  button lights when the microphone is off.
- Press  again to turn the microphone on.
- Use  on handset, Handsfree or headset calls.

## Time offset

When your i2004 Internet Telephone is located in a different time zone from your system, the display shows the system time not the local time. The Time Offset feature allows you to adjust the time that appears on the display.

Before you begin, calculate the time difference, in hours, between the server time and local time. To change the time that appears on your telephone display to local time:

- 1 Press **Feature**    .
- 2 Press **HANGE**.
- 3 Press  to switch between adding or subtracting time.
- 4 Using the dialpad, enter the number of hours between local time and system time.  
**Note:** Press  to enter half hour increments.
- 5 Press **OK**.

**Note:** It may take up to one minute for the change to appear on the display.

## Navigation buttons

Use the Navigation buttons to scroll through or make changes to your call log.



- 1 Press **Feature**   .





## Call log

Call Log displays use the following special characters:

- (underline) identifies a new item
- ∩ identifies answered calls
- ≡ identifies long distance calls
- \* identifies that the information has been shortened

To view your Call Log:



- 1 Press  to view old items.  
Press  to view new items.  
Press  to return to the last viewed item.

- 2 Press  and  to move through your items.
- 3 Press  and  to view more information on an item.

To erase a Call Log entry:

- 1 Press  while viewing an item.

To return a call from your Call Log:

- 1 Display the desired number on your telephone.
- 2 Edit the number, if required. You can add numbers for long distance dialing or line pool access or remove numbers using  and .
- 3 Press a line button.
- 4 Lift the handset.



## Memory buttons

This chapter contains information about the i2004 Internet Telephone memory buttons and how to use them. These are buttons not assigned as line or intercom buttons. Memory buttons store internal and external numbers or features to give you one touch dialing or feature activation.



### Program memory buttons

You can program a memory button with a new number or feature.

#### External autodial

- 1 Press **Feature**  .
- 2 Press a memory button.
- 3 Dial the external number.
- 4 Press **OK** to store the number.

#### Internal autodial

- 1 Press **Feature**  .
- 2 Press a memory button.
- 3 Dial the extension number.
- 4 Press **OK** to store the number.

## Features

- 1 Press Feature \* 3 .
- 2 Press a memory button.
- 3 Press Feature and enter the feature code.
- 4 Press OK to store the feature code.

## Erase memory buttons

- 1 Press Feature \* 1 .
- 2 Press a memory button.
- 3 Press OK to erase the button.

